

**SPECIFICATIONS**

CT80 Handle (CTLH001):

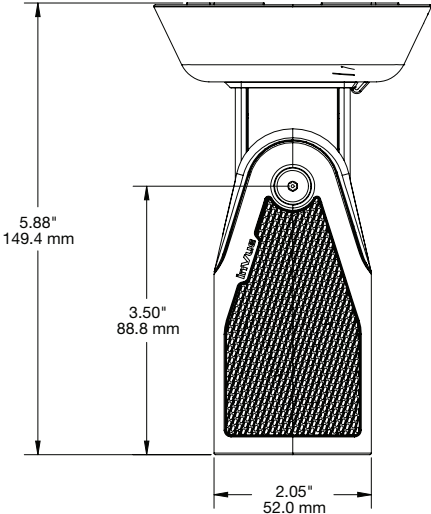
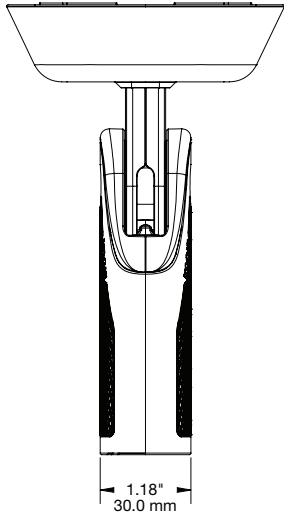
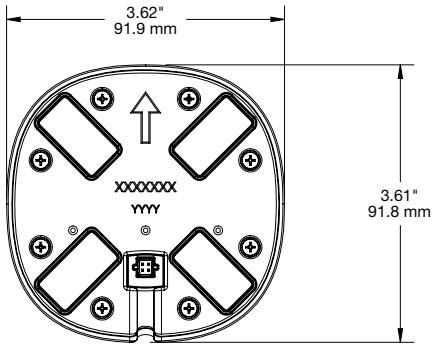

## SPECIFICATIONS

CT80 Base (CTLB001):

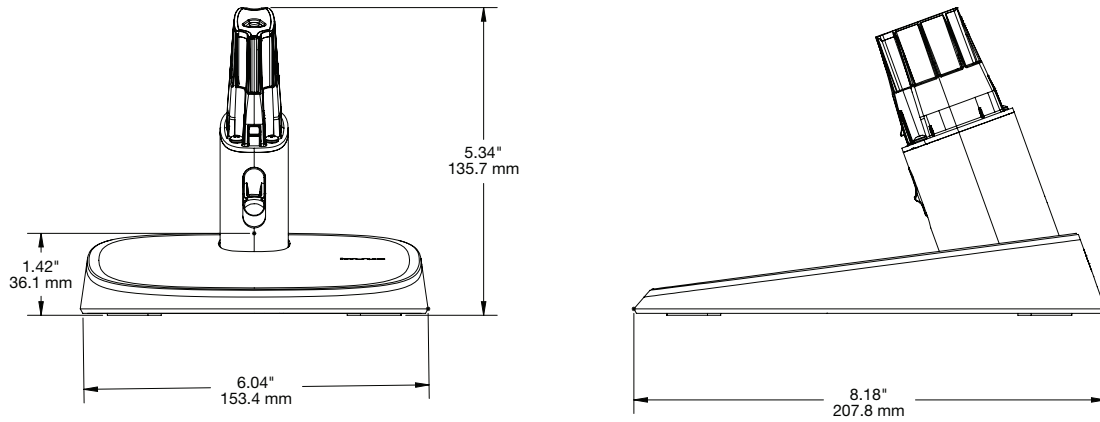

CT80 Cable Management Clips (CTLA001):

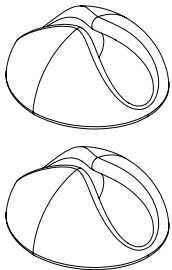

CT80 Replacement Key (CTLA002):

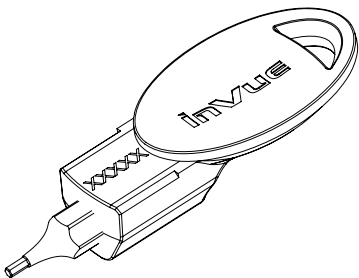

**SPECIFICATIONS**

CT80 Ingenico Moby Series Bracket (CTBA010-B)

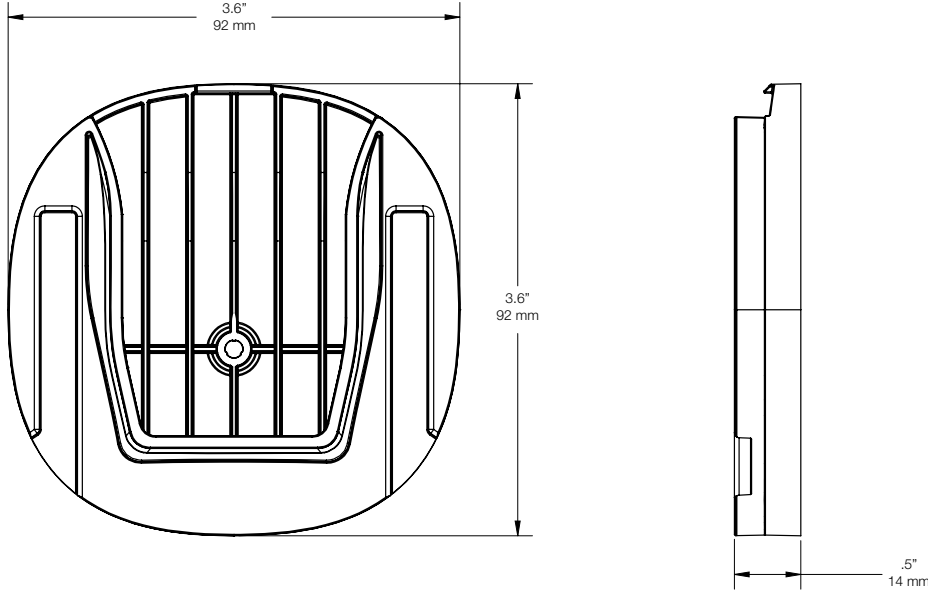

**SPECIFICATIONS**

CT150 Counter Stand, Latch (CTBL001):

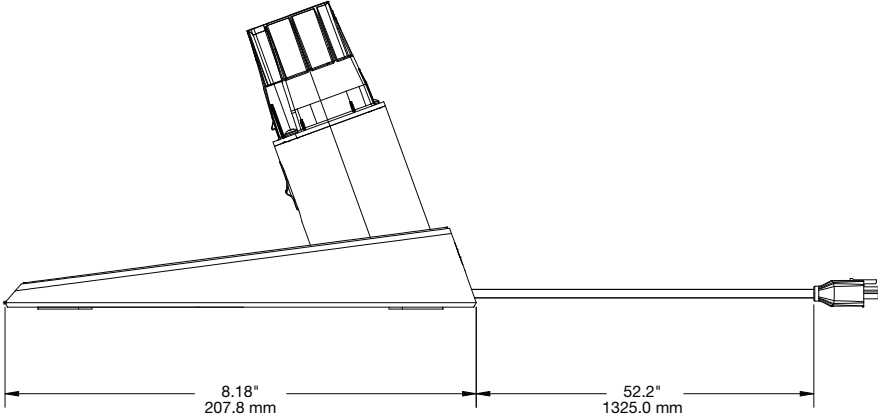
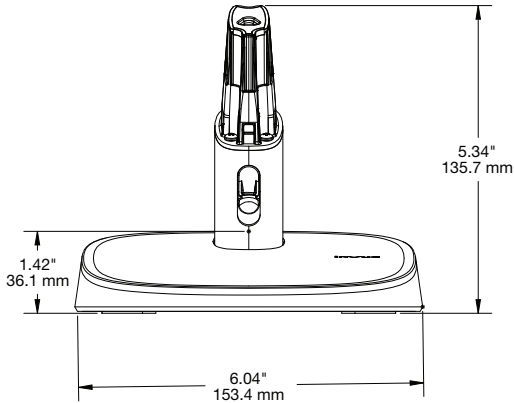

**SPECIFICATIONS**

CT150 Wall Mount, Latch (CTBL002):

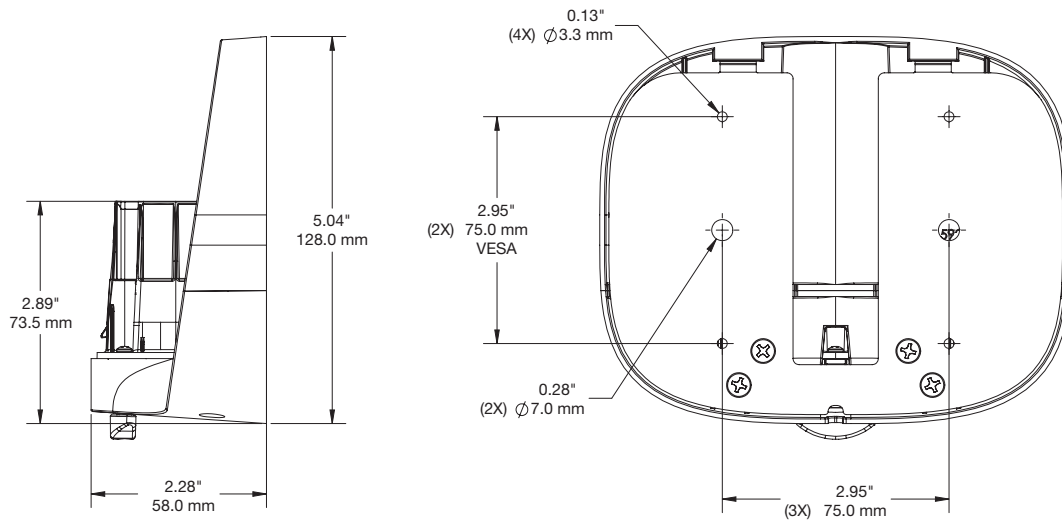
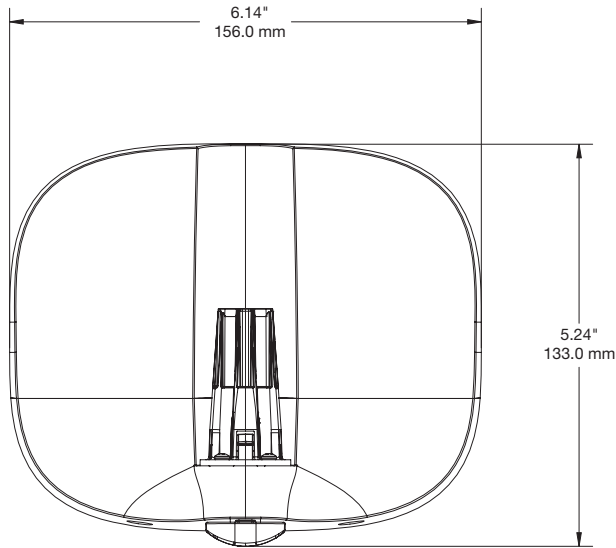

**SPECIFICATIONS**

CT150 Counter Stand IR (CTBR001):

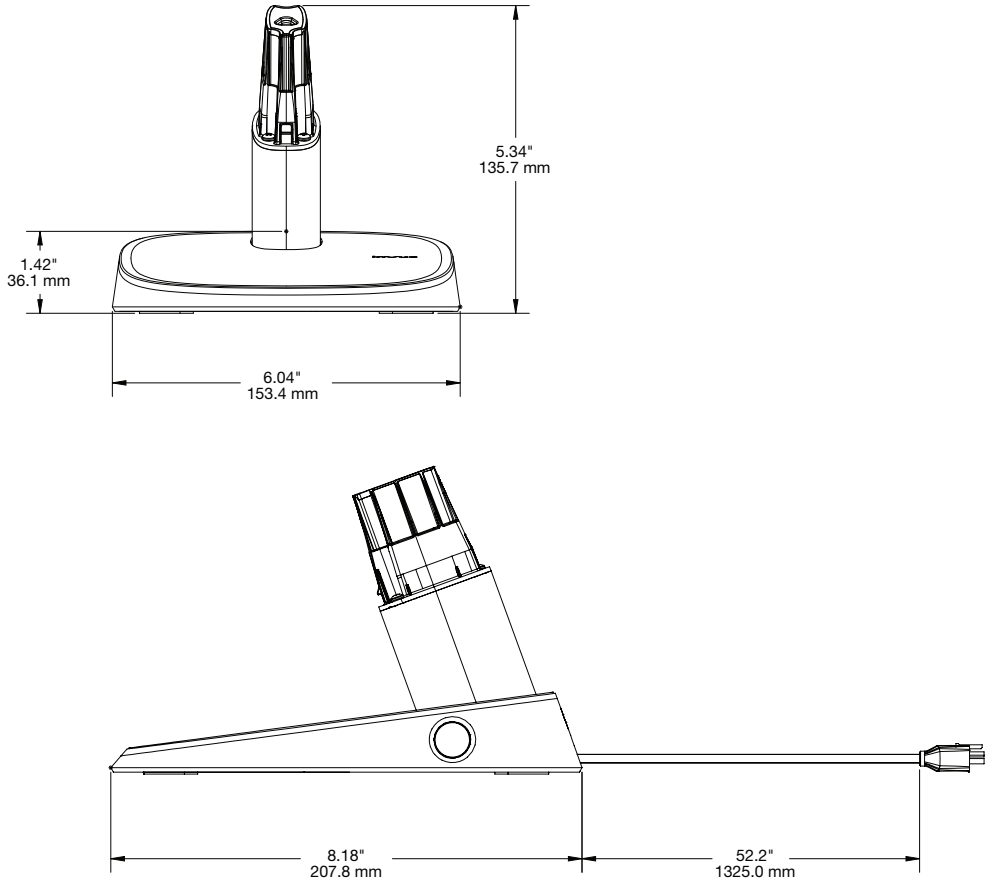

**SPECIFICATIONS**

CT150 Tablet Handle (CTBH001):

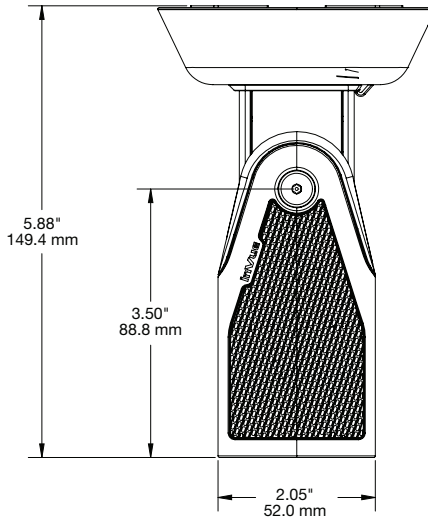
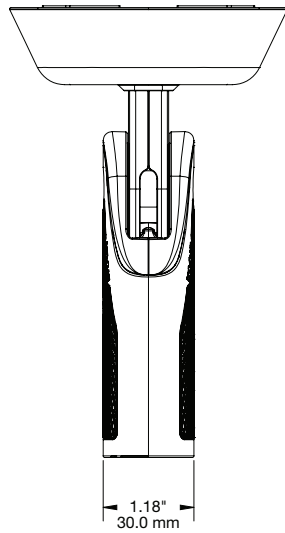
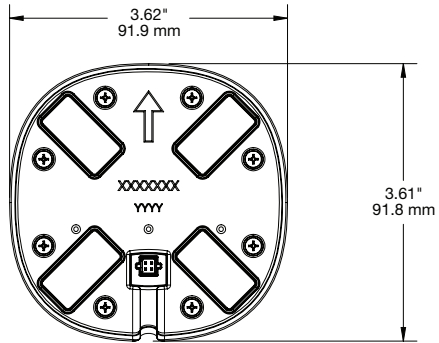

**SPECIFICATIONS**

CT150 MFI Lightning Cable Kit (CTBA001):

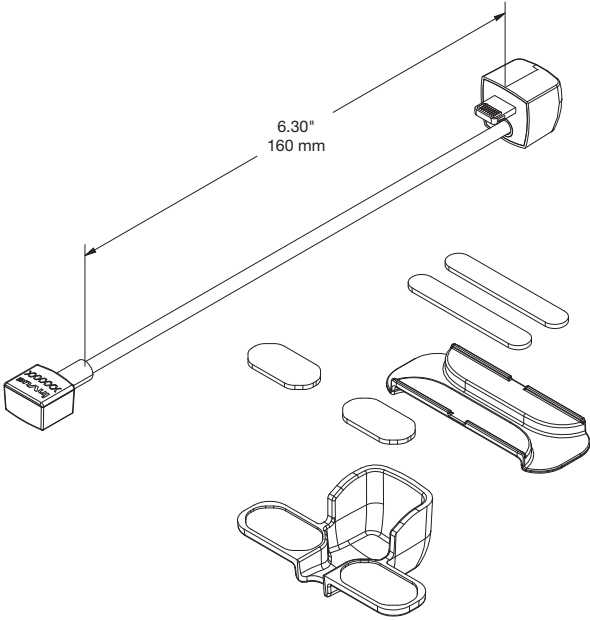

CT150 USB-C Cable Kit (CTBA002):

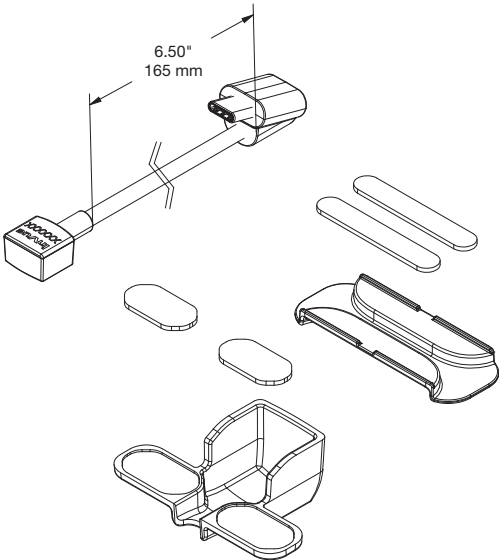



## SPECIFICATIONS

CT150 Micro USB Cable Kit (CTBA003):

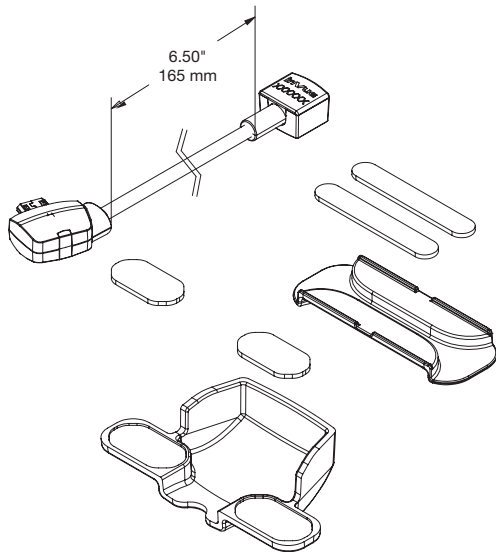

CT80/CT150 Bolt Mount Kit (CTBA004):

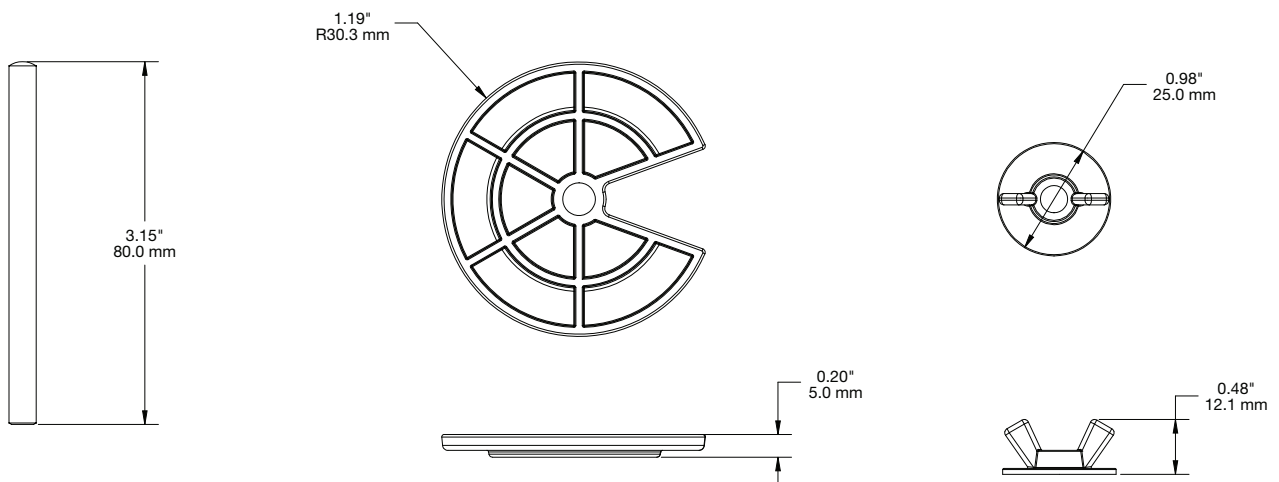

**SPECIFICATIONS**

CT150/CT100 Magtek iDynamo Mount (CTBA007) (for use with Apple iPads only):

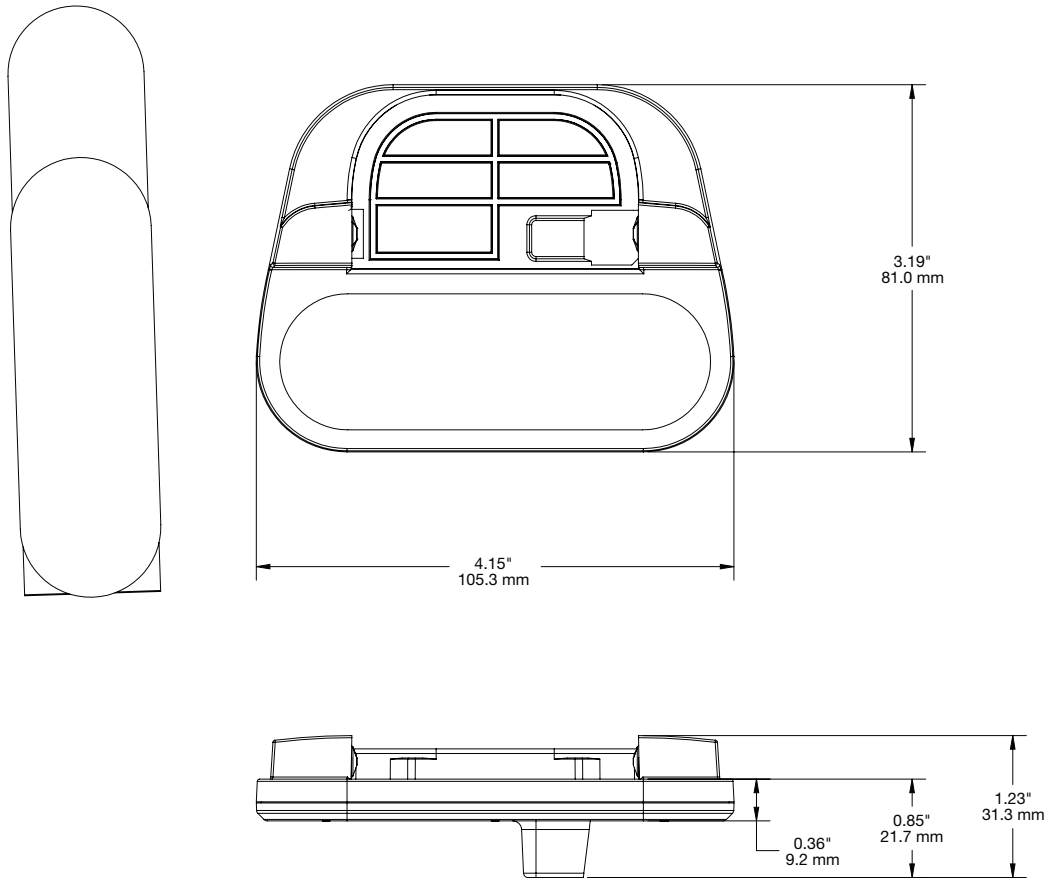

CT80/CT150 Stand and Handle Replacement Adhesive (ADH2165):

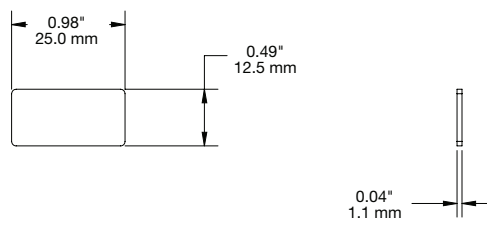

**SPECIFICATIONS**

CT80/CT150 Frame iPad Air 2/9.7 5 & 6 Ingenico RP457c (CTBA011-B)

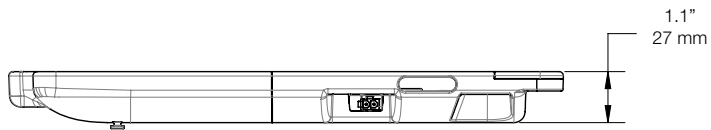
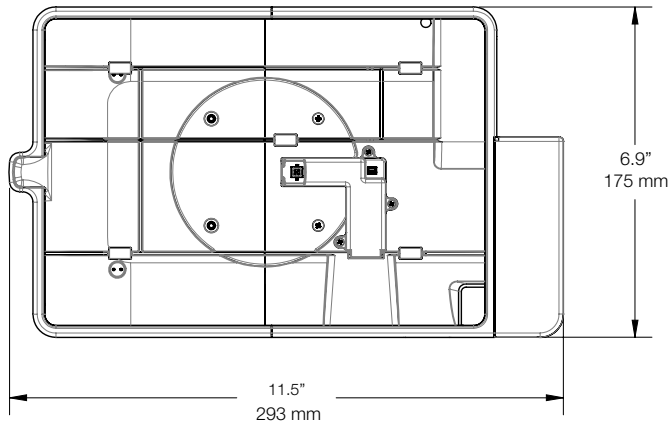

CT150 Handle Cable (CTBA013-B):

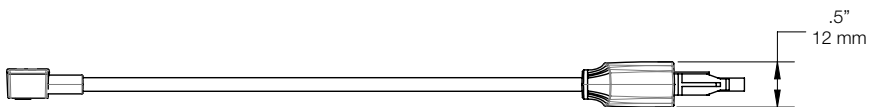
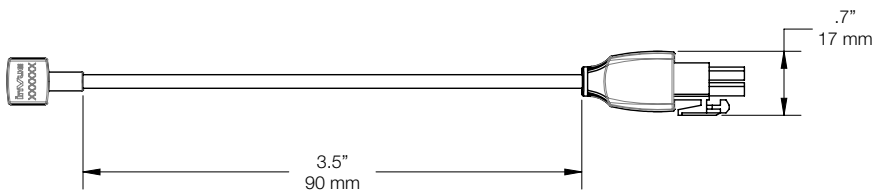

## PRODUCT ORDERING

ORDER CODE	DESCRIPTION	NOTES
<b>CT80 KITS</b>		
CT80 Counter KT04234	CT80 System - Black	› Includes base (CTLB001) and handle (CTLH001), key and cable clips
CT80 Counter KT04693	CT80 Counter - Black w Ingenico Moby	› CT80 counter system with bracket to support Ingenico Moby M70, M100 and M120. Includes all items in CT80 Counter plus the Moby Mx bracket
<b>CT80 INDIVIDUAL PARTS</b>		
CTBA010-B	CT80 Ingenico Moby Series Bracket	CT80 replacement bracket for Ingenico Moby M70, M100, M120
CTLH001-B	CT80 Handle - Black	
CTLB001-B	CT80 Base - Black	
CTLA001-B	CT80 Cable Management Clips - Black	› Two (2) replacements
CTLA002	CT80 Replacement Key	› 1.5mm hex
CTBA004	CT80/CT150 Bolt Mount Kit	
ADH2165	CT80/CT150 Stand and Handle Replacement Adhesive	
DNTX93	Scoop Blade Adhesive Removal Tool CT80/CT150	› Multitool is required (AF6313)
HC7430	Optional LSE Adhesive Pads for CT80/CT150	

White available as BTO



## PRODUCT ORDERING

ORDER CODE	DESCRIPTION	NOTES
<b>CT150 KITS</b>		
CT150 Counter KT04231	CT150 Counter Mount System - Black	› Includes base (CTBL001) and handle (CTBH001)
CT150 Wall KT04232	CT150 Wall Mount System - Black	› Includes wall mount (CTBL002) and handle (CTBH001)
CT150IR Counter KT04233	CT150 IR Counter Mount System - Black	› Includes base (CTBR001) and handle (CTBH001)
<b>CT150 INDIVIDUAL PARTS</b>		
CTBL001-B	CT150 Counter Stand, Latch - Black	
CTBL002-B	CT150 Wall Mount, Latch - Black	
CTBR001-B	CT150 Counter Stand IR - Black	
CTBH001-B	CT150 Tablet Handle - Black	
CTBA001-B	CT150 MFI Lightning Cable Kit - Black	
CTBA002-B	CT150 USB-C Cable Kit - Black	
CTBA003-B	CT150 Micro USB Cable Kit - Black	
CTBA011-B	CT80/CT150 Frame iPad Air 2/9.7 5 & 6	› Supports Ingenico RP457c
CTBA013-B	CT150 Handle Cable	› Required for CTBA011
CTBA004	CT80/CT150 Bolt Mount Kit	
CTBA007	CT150/CT100 Magtek iDynamo Mount	› For use with Apple iPads only
ADH2165	CT80/CT150 Stand and Handle Replacement Adhesive	
DNTX93	Scoop Blade Adhesive Removal Tool CT80/CT150	› Multitool is required (AF6313)
HC7430	Optional LSE Adhesive Pads for CT80/CT150	
PS24VUS PS24VEU PS24VAUS PS24VUK	24V Power Supply Kit with US blades 24V Power Supply Kit with EU blades 24V Power Supply Kit with AUS blades 24V Power Supply Kit with UK blades	
PS536	1.8m Extension Cable, PS531 to CTBA011-B	› Required if using CTBA011 without CT150 stand. Use with power supply PS531
PS531 - US/AUS/ EU/IND/JPN/KR/UK	5V, 3A (5 PIN) Power Supply	› Required if using CTBA011 without CT150 stand. Use with cable PS536.

White available as BTO



---

### ENVIRONMENTAL SPECIFICATIONS

*Operating Temperature:* 0°C 0% RH to 40°C and 80%RH

*Shipping and Storage Specifications:* -20°C and 0%RH and 72 hours at 70°C and 85%RH

---

### POWER SUPPLY SPECIFICATIONS

#### **CT150 Stand:**

*AC/DC Adaptor (Power Supply)(PS24V-XX):*

› *Input:* 115-220VAC @ 50-60Hz

› *Output:* 45 Watts: 5V, 9V, 12V, & 15V devices up to 3 Amps

invue.com

---

©2018 InVue Security Products. No endorsement of InVue products has been made by any of the manufacturers of the products shown. Product is sold pursuant to InVue's warranty which can be found at [www.invue.com/warranty](http://www.invue.com/warranty).

**THE AMERICAS** 704.752.6513 • 888.55.INVUE

**EUROPE, MIDDLE EAST & AFRICA** +31.23.8900150

**ASIA PACIFIC** +852.3127.6811

